

Tommaslide 100

Straight Sliding Door System



Tommaslide 100 is a modern top hung sliding door system that can be operated with a weightless fingertip effort, producing a consistent smooth operating lifecycle for panels weighing up to 100kg.

The Tommaslide can be Soffit fixed to your door frame or Face fixed to the side of your wall. All Tommaslide rollers are tested to 100,000 cycles and come with a 10 year warranty.

- Maximum Door Weight without Soft Close: 100kg
- Maximum Door Weight with Soft Close: 80kg
- Minimum Panel Width with Soft Close and Open: 762mm wide
- Minimum Panel Width with Soft Close: 370mm wide
- Minimum Door Thickness: 30mm thick



Maximum door panel weight of 100kg.



Featuring high quality components



Smooth gliding action when operating



Full technical support



Soffit fixed or Face Fitting



FastFix or Full Height Brackets

10 year warranty
on all Tommaslide rollers

Door Bracket Choices

Fastfix Bracket

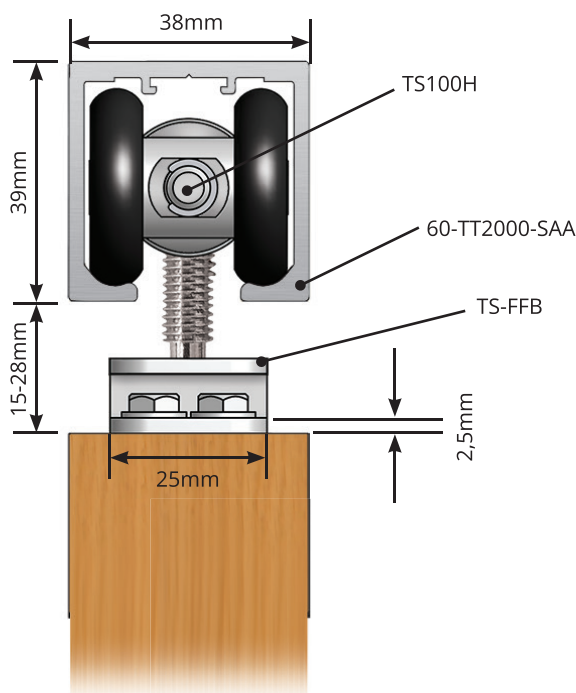

Fullheight Bracket

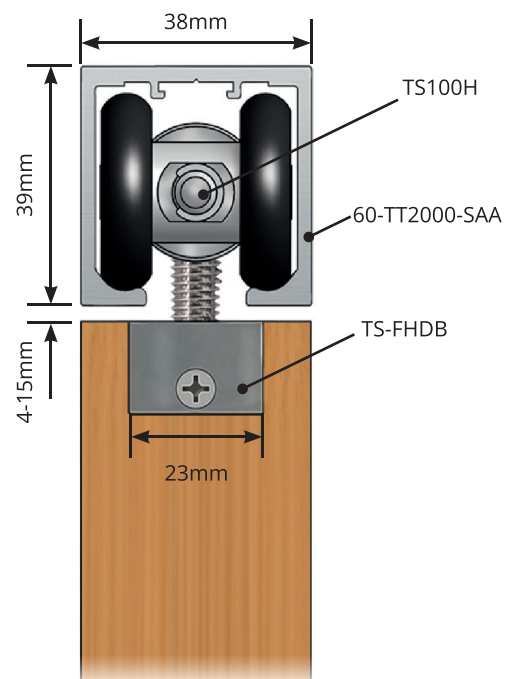

Tommaslide 100 Specification

Fastfix without Softclose Kit Components

High Impact Door Stop



x2

Code: TS100DS

4 Wheeled Door Hanger



x2

Code: TS100H

FastFix Bracket



x2

Code: TS-FFB

Kit Code	Stops	Hangers	FastFix Brackets
TS100FFD/0	2 x TS100DS	2 x TS100H	2 x TS-FFB

Screws are included with all kits - TS-FFB-SC | Spanner is also included - TS-SPAN-PRES

Fastfix Softclose Kit Components

High Impact Door Stop



x1

Code: TS100DS

4 Wheeled Door Hanger



x1

Code: TS100H

FastFix Bracket



x2

Code: TS-FFB

Softclose



x1

Trigger Plate
TSSCT

Code: TS100SC-__

Door Weight	Kit Code	Stops	Hangers	Bracket	Softclose	
0-20kg	TS100FFD/1-20	includes	1 x TS100DS	1 x TS100H	2 x TS-FFB	1 x TS100SC0-20
20-40kg	TS100FFD/1-40		1 x TS100DS	1 x TS100H	2 x TS-FFB	1 x TS100SC20-40
40-60kg	TS100FFD/1-60		1 x TS100DS	1 x TS100H	2 x TS-FFB	1 x TS100SC40-60
60-80kg	TS100FFD/1-80		1 x TS100DS	1 x TS100H	2 x TS-FFB	1 x TS100SC60-80

Screws are included with all kits - TS-FFB-SC | Spanner is also included - TS-SPAN-PRES

Full Height without Softclose Kit Components

High Impact Door Stop



x2

Code: TS100DS

4 Wheeled Door Hanger



x2

Code: TS100H

Full Height Bracket



x2

Code: TS-FHDB

Kit Code	Stops	Hangers	Full Height Brackets
TS100FD/0	2 x TS100DS	2 x TS100H	2 x TS-FHDB

Screws are included with all kits - TS-FFB-SC | Spanner is also included - TS-SPAN-PRES

Tommaslide 100 Specification

Full Height Softclose Kit Components

High Impact Door Stop

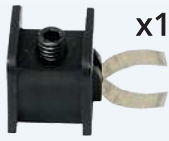

x1

Code: TS100DS

4 Wheeled Door Hanger



x1

Code: TS100H

FastFix Bracket



x2

Code: TS-FFB

Softclose



x1

Code: TS100SC_

Trigger Plate
TSSCT

Door Weight	Kit Code	Stops	Hangers	Bracket	Softclose	
0-20kg	TS100FFD/1-20	Includes	1 x TS100DS	1 x TS100H	2 x TS-FHDB	1 x TS100SC0-20
20-40kg	TS100FFD/1-40		1 x TS100DS	1 x TS100H	2 x TS-FHDB	1 x TS100SC20-40
40-60kg	TS100FFD/1-60		1 x TS100DS	1 x TS100H	2 x TS-FHDB	1 x TS100SC40-60
60-80kg	TS100FFD/1-80		1 x TS100DS	1 x TS100H	2 x TS-FHDB	1 x TS100SC60-80

Screws are included in kit - TS-FFB-SC | Spanner is also included - TS-SPAN-PRES

Fastfix Softclose and Open Kit Components

FastFix Bracket



x2

Code: TS-FFB

Softclose



x2

Code: TS100SC_

Trigger Plate
TSSCT

Trigger Plate



x2

Code: TSSCT

Door Weight	Kit Code	Bracket	Softclose	
0-20kg	TS100FFD/2-20	Includes	2 x TS100SC0-20	
20-40kg	TS100FFD/2-40		2 x TS-FFB	2 x TS100SC20-40
40-60kg	TS100FFD/2-60		2 x TS-FFB	2 x TS100SC40-60
60-80kg	TS100FFD/2-80		2 x TS-FFB	2 x TS100SC60-80

Screws are included with all kits - TS-FFB-SC | Spanner is also included - TS-SPAN-PRES

Full Height Softclose and Open Kit Components

FastFix Bracket



x2

Code: TS-FFB

Softclose



x2

Code: TS100SC_

Trigger Plate



x2

Code: TSSCT

Door Weight	Kit Code	Bracket	Softclose	
0-20kg	TS100FFD/2-20	Includes	2 x TS100SC0-20	
20-40kg	TS100FFD/2-40		2 x TS-FHDB	2 x TS100SC20-40
40-60kg	TS100FFD/2-60		2 x TS-FHDB	2 x TS100SC40-60
60-80kg	TS100FFD/2-80		2 x TS-FHDB	2 x TS100SC60-80

Screws are included in kit - TS-FFB-SC | Spanner is also included - TS-SPAN-PRES

Tommaslide 100 Specification

Top Track Satin Aluminium

Length	Code
2m	60-TT2000-SAA
3m	60-TT3000-SAA
4m	60-TT4000-SAA
6m	60-TT6000-SAA

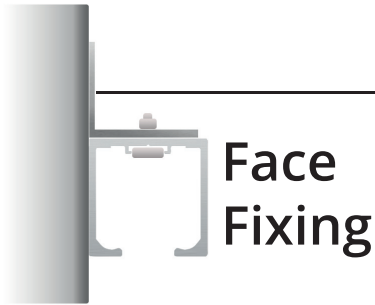
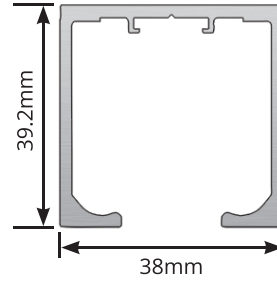

Face Fixing



Face Fixing Bracket
Bolts and Nuts
Included

Code: TSFFB

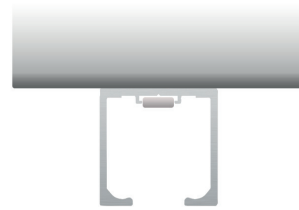

Soffit Fixing

Bottom Track Satin Aluminium

Length	Code
2m	10-60-BT2000-CA
3m	10-60-BT2000-CA
4m	10-60-BT4000-CA
6m	10-60-BT6000-CA

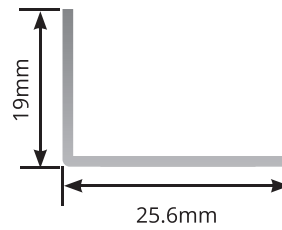

Bottom Guides

Single Bearing Guide

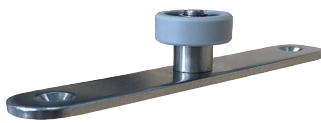

Code: TS-SBG

Single Guide



Code: TS-NG

Floor Guide



Code: TS-FG

To suit doors between
30 & 60mm

